

承認書

APPROVAL SHEET

承認書編號:

SHEET NO: NDJF1526011001

客 戶

CUSTOMER

品 名

PARTNAME

JF15-302 HLOWH15.6

訂 單 號

PURCHASE ORDER

客 戶 料 號

CUSTOMER'S PART NO.

日 期

DATE

2026/4/9

客戶承認

Customer Approved by

供應商經辦

Supplier Handle by

發行章

*** 承認後請回簽一份 Please sign back after approval. THANKS!**

香港公司 HONG KONG OFFICE:
新昌電子(香港)有限公司
XINCHANG ELECTRONIC(HK) LIMITED
ADD: RM A10, 13/F, WAH WAI IND.
BLDG., 1-7 WO HEUNG ST.,
FO TAN, SHATIN, HK
香港沙田火炭禾香街 1-7 號
華威工業大廈 13 樓 A10 室
E-mail: cynthia@gk-xc.com

常州工廠 CHANGZHOU FACTORY:
江蘇國科新昌科技有限公司
JIANGSU GUOKE XINCHANG
TECHNOLOGY CO., LTD
常州市新昌電子有限公司
CHANGZHOU XINCHANG ELECTRONIC
CO., LTD
ADD: NO. 5 CHENGHE RD., LIJIA
TOWN, CHANGZHOU, JIANGSU
江蘇省常州市武進區禮嘉鎮
城河路5號

E-mail:
hong_yin@gk-xc.com
http://: www.gk-xc.com

東莞工廠 DONGGUAN FACTORY:
東莞常新昌電子有限公司
DONGGUAN CHANGXINCHANG
ELECTRONIC CO., LTD
ADD: RM 102, NO. 12 JIYUAN ST.,
SHIJIE TOWN, DONGGUAN,
GUANGDONG
廣東省東莞市石碣鎮吉源街
12號102室
E-mail: tangfm@gk-xc.com

霍尔摇杆规格书

Hall Joystick specs

适用机型：JF15 系列

日期：2026 年 4 月 9 日

1.General 一般事项

1.1 Scope 适用范围

This specification is applicable to electromagnetic joystick used in electronic equipment. Under the specified operating conditions, the three-axis linear digital output magnetic sensor inside the joystick can obtain valid three-axis magnetic field measurement data through the IIC interface.

本规格书适用于电子设备使用之电磁摇杆。在规定的工作条件下，摇杆内部的三轴线性数字输出磁传感器可以通过 IIC 接口获取有效的三轴磁场测量数据。

1.2 Standard atmospheric conditions 标准大气状态

Unless otherwise specified, the standard range of atmospheric conditions for making measurements and tests is as follows:

除另有规定外，量测应在以下大气条件下进行：

Ambient temperature : 15°C ~ 35°C

温度

Relative humidity : 25% ~ 85%

相对湿度

Air pressure : 86 KPa~ 106 KPa

气压

If there is any doubt about the results, measurements should be made within the following limits:

如有任何疑虑时，量测应在以下条件下进行：

Ambient temperature : 20°C ± 1°C

温度

Relative humidity : 63% ~ 67%

相对湿度

Air pressure : 86 KPa~ 106 KPa

气压

1.3 Operating temperature range : -10°C ~ +70°C

适用温度范围

1.4 Storage temperature range : -30°C ~+80°C

保存温度范围

1.5 Operators shall wear electrostatic bracelets during operation

作业员操作时需戴静电手环

1.6 Construction 构造

Dimension 尺寸 : Refer to attached drawing 参见成品图

2. Mechanical Characteristics		2. 机械特性	
NO. 序号	Item 项目	Measuring condition 测试条件	Specifications 规格
	Figure of lever operation 摇杆动作形式	/	Circular operating 圆形式
2.1	Operation angle of lever 摇杆使用有效角度	Add a fit force on the lever top to push it to max,angle of each direction when lever is released and reset position . 当摇杆处于自由复归位置时，在摇杆顶部施加一定力将摇杆推向任意方向最大角度。	27° max 最大 27°
2.2	Operating force of lever 摇杆作用力	Test position is at more than 10 degrees deflection of lever 摇杆偏斜 10 度以上之位置测定	65±25 gf
2.3	Knob strength 扭曲强度	Apply force on the lever perpendicular to the lever's rotation direction 旋转于摇杆的力作用于摇杆上	More than 2Kgf.cm 3 seconds min 大于 2Kgf.cm 至少 3 秒钟
2.4	The stopper strength of the lever 摇杆止动强度	Apply side force on the lever perpendicular to the lever 's axial direction 垂直于摇杆的力作用于摇杆上	More than 2Kgf 3 seconds min 大于 2Kgf, 至少 3 秒钟
2.5	Accuracy of reset position of lever 摇杆复归精度	Measure the angle between the lever and the axial center line after the lever pushed to the direction of X-X(Y-Y)and resets 摇杆推向 X-X(Y-Y)方向自由复归后测量摇杆与垂直中心线的角度。	±3°
2.6	Pull strength of lever 摇杆拉拔强度	Apply specified push force on the lever upward 作用于摇杆上，沿摇杆方向向上	More than 5Kgf 3 seconds min 大于 5Kgf, 至少 3 秒钟

NO. 序号	Item 项目	Measuring condition 测试条件	Specifications 规格
2.7	Push Strength of lever 摇杆推强度	Apply specified push force on the lever downward 作用于摇杆上，沿摇杆方向向下	More than 5Kgf 3 seconds min 大于 5Kgf,至少 3 秒钟
2.8	Switch operating force 开关作动力	Apply side force perpendicular to the lever's axial direction on the lever until the lever stops ,measure the max force value 将一个轴向的力施加于摇杆上，直到其不动为止，量取施力期间之最大值。	500±200 gf
2.9	Switch travel 开关行程	Put the switch lever upward ,apply 2 times of the static operating force over the lever's axial direction of the lever,measure the variance of the switch stroke. 将开关操作部位（摇杆）置于静止位置，并在操作柄中央施加两倍于作动力之静负荷测量柄被压到不动时之移动距离。	0.3+0.1/-0.2mm

3. Electrical characteristics

3. 电气特性

NO. 序号	Item 项目	Measuring condition 测试条件	Specifications 规格
3.1	Switch contact resistance 开关接触阻抗	Apply 2tine of the operating force of the static load on the vertical direction of the lever ,measure the resistance by using the Contact Resistance Tester with 1KHZ,20mV,5-50mA of current. 将两倍于作动力之静负荷加于操作柄之中央以（1KHZ,20mV,5-50mA)微电流接触阻抗计测定。	Less than 200 Ω 低于 200 Ω
3.2	Insulation resistance 绝缘阻抗	/	More than 10M Ω 10M Ω 以上

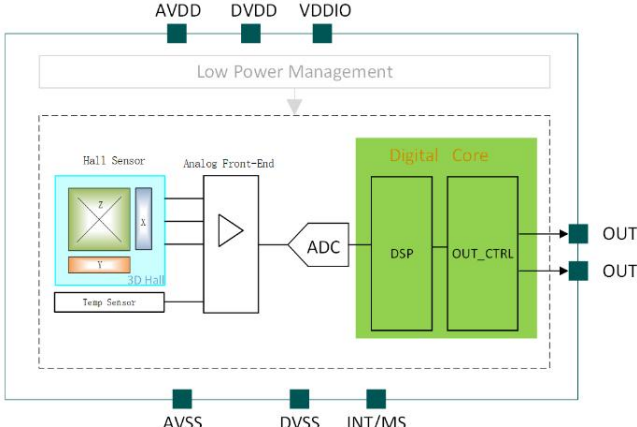
NO. 序号	Item 项目	Measuring condition 测试条件	Specifications 规格
3.3	Voltage Divider Error 分压误差值	Voltage divider error is defined the ratio of the voltage terminals 1-2 to terminals 1-3 after the drive arm rested. 3.3V & 5V D.C. shall be applied to the terminals between 1 and 3 and then voltage divider error shall be measured with the drive arm operation on the line X-X and Y-Y. 分压误差值是摇杆自由复归后端子1-2与端子1-3电压比例。将3.3V&5V D.C电压加在端子1-3之间,分压误差值在摇杆动作于X-X和Y-Y方向到底复归后测试。(端子1-2/端子1-3×100%)	47%~53%
3.4	Limit voltage value 极限电压值	The limit voltage value is the voltage ratio between terminals 1-2 and 1-3 after the rocker reaches the bottom Add 3.3V & 5V D.C voltage between terminals 1-3, and the limit voltage rocker operates in the x-x and Y-Y directions to the bottom 极限电压值是摇杆到底后端子1-2与端子1-3电压比例,将3.3V&5V D.C电压加在端子1-3之前,极限电压摇杆运作于X-X和Y-Y方向到底测试。	最小值≤20%, 最大值≥80% (可依需求编辑极限电压)
3.5	error value of reset position of lever 摇杆复归误差值	Measure the voltage difference after the joystick is pushed towards the X-X (Y-Y) direction for free reset. 摇杆推向 X-X(Y-Y)方向自由复归后测量电压差。	±3% V 总
3.6	Functional Block Diagram 功能图		

		Symbol 符号	Parameters 参数	Test Condition 实验条件	Min 最小值	Typ 标准值	Max 最大值	Unit 单位
3.7	Electrical Specificati 电气规格	Vcc	Supp ly Voltage 电源电压		2.8	-	5.5	V
		Icc	Supp ly Current 供电电流	Ta=25 ℃	-	3.8	-	mA
		Tpo	Power on Time 开机时 间	Ta=25 ℃	-	20		MS
		Bw	Bandwidth 带宽	-3dB, CL=1nF	-	1000	-	Hz
		VOL	L inear output low voltage 线性输 出低电 压(可编程)	VCC=3.3V, RL>= 10K Ω	-	-	0.1	V
		VOH	L inear output high voltage 线性输 出高电 压(可编 程)	VCC=3V, RL >=10 K Ω	VCC-0. 1	-	-	V
		VN	Noise 噪 声	Ta=25℃ , Vcc= 1.8V, BW=1000Hz	-	6	-	mVpp
		3.8	Magnetic Characteris tics 磁特性	Symbol 符号	Parameters 参数	Test Condition 实验条件	Min 最小值	Typ 标准值
RES _{XYZT}	XYZ 磁场与温度 分辨率					12		Bit
M _{XYrange}	XY 轴磁场线性范 围			Gain=20	-130	-	130	mT

		M _{Zrange}	Z 轴磁场线性范围	Gain=20	-80	-	80	mT
		SENS(T)	SENS Variation Over Temperature 传感器随温度的变化	开启温度补偿	-1.5	-	1.5	%
3.9	V ESD 耐静电	Type 类型		REFERENCE 参考		typical value 典型值		
		Human-body model (HBM) 人体类型		ESDA/JEDEC JS-001-2017		±5KV		
		Charged-device model (CDM) 带电器件模型		ESDA/JEDEC JS-002-2018		±1KV		
		sealing effect (Latch up) 闭锁效应		JESD78E		200mA		
4. Endurance				4. 耐久特性				
NO. 序号	Item 项目	COND IT IONS 条件				Specifications 规格		
4.1	Dry heat 耐热性	Temperature:80±2℃ Time:96 hours The controller shall be subjected to standard atmospheric conditions for 2 hours,after which measurement shall be made. 在温度 80±2℃ 恒温槽中放置 96 小时，取出后在正常状态下放置 2 小时后测试。				No bad performance and switch performance damage 无不良性能产生及开关性能损坏		
4.2	Damp heat 耐湿性	Temperature: 60±2℃ Humidity : 90~95%Rh Time :96 hours Surface moisture shall be removed And then the controller shall be subjected to standard atmospheric conditions for 2hours,after which measurement shall be made. 温度 60±2℃ 90%~95%Rh 恒温槽中放置 96 小时，表面水份摄取后在正常状态下放置 2 小时后测试。				No bad performance and switch performance damage 无不良性能产生及开关性能损坏		
4.3	Cold 耐寒性	Temperature : -30±2℃ Time : 96 hours Surface moisture shall be removed ,and then controller shall be subjected to standard atmospheric conditions for 2 hours,after which measurement shall be made . 在温度-30±2℃ 恒温槽中放置 96 小时，表面水份摄取后在正常状态下放置 2 小时后测试。				No bad performance and switch performance damage 无不良性能产生及开关性能损坏		

NO. 序号	Item 项目	Measuring condition 测试条件	Specifications 规格
4.4	Temperature cycling test 温度循环测试	Low temperature :-20±3℃ 30minutes High temperature :+60±3℃30minutes Number of cycles:5 Surface moisture shall be removed,and then the controller shall be subjected to standard atmospheric conditions for 2 hours,after which measurement shall be made . 在低温为-20±3℃恒温槽放置 30 分钟，高温 60±3℃放置 30 分钟，测试 5 次，表面水份摄取后在正常状态下放置 2 小时后测试。	No bad performance and switch performance damage 无不良性能产生及开关性能损坏
4.5	Free falling 自由落下试验	Height:75cm. Number of falls:3 times 从高度为 75 厘米落下测试 3 次后。	No bad performance and switch performance damage. 无不良性能产生及开关性能损坏
4.6	Number of cycles 耐久寿命	Mechanical life should be tested 3,000,000 cycles at the speed of one cycle per second without electrical load when joystick rotate 360 °at 27 °position. 无负载状态下以 1 圈/秒速度将摇杆推到 27 °位置进行 360 °旋转测试，寿命 3, 000, 000 圈	Without mechanical malfunction 机械性能无异常
4.7	Switch number of cycles 开关寿命	Under electrical load DC5V/5MA,compress 500gf force to the lever which is released and reset to vertical position .Switch life should be tested more than 500,000 cycles at the the speed of 2 cycles of 2 cycles per second . 负载状态下（DC5V/5mA）,在摇杆自由复归后的垂直方向施加 500gf 的按压力，以 2 次/秒的速度对开关进行测试，寿命 500, 000 次以上。	Contact resistance 200ΩMax,No mechanical malfunction Be satisfied with 2.8 and 2.9 接触阻抗最大 200 Ω，机械方面能动作（符合第 2.8 条和第 2.9 条

印 章	日期：2026-4-9 江苏国科新昌科技有限公司 常州市新昌电子有限公司	

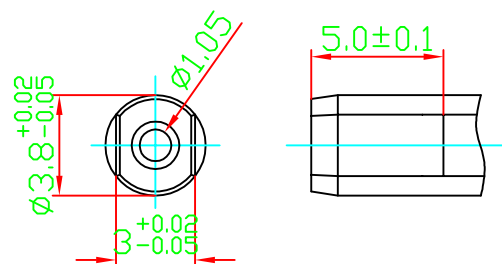
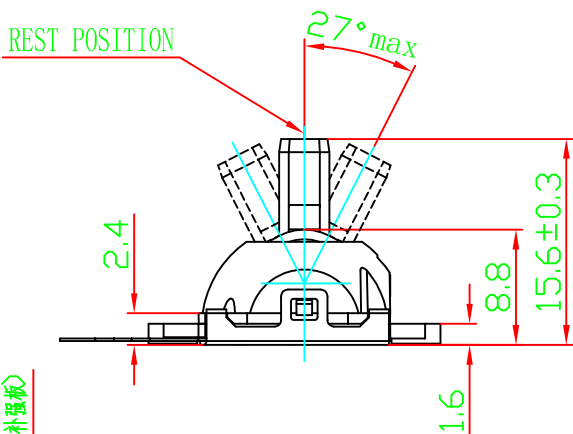
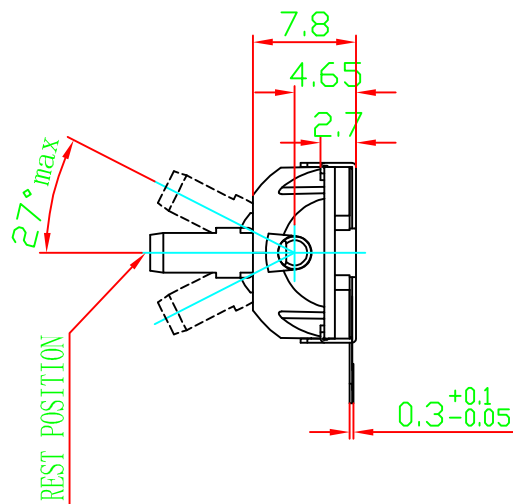
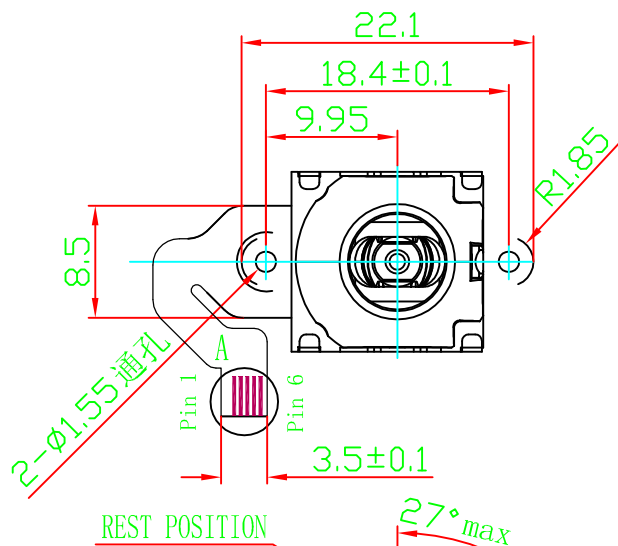

推柄局部尺寸详图
2:1

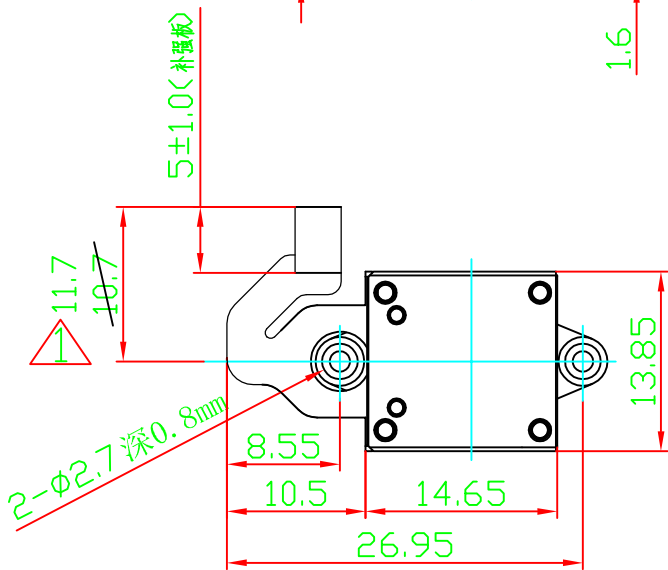

- CIRCUIT
- Pin 1(空)
 - Pin 2(OUT1)
 - Pin 3(Switch)
 - Pin 4(GND)
 - Pin 5(VCC)
 - Pin 6(OUT2)

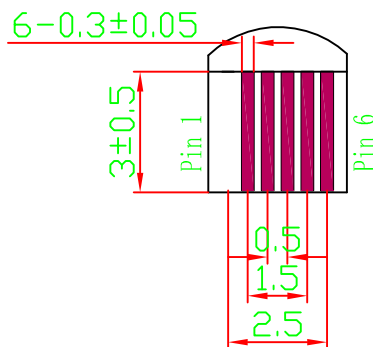

A局部视图
3:1

			江苏国科新昌科技有限公司 常州市新昌电子有限公司		
			Projected view	機種 JF15霍尔摇杆	
NO.	DESCRIPTION	DATE	TOL UNLESS OTHERWISE STATED		
			X < 10 ±0.3	品名 JF15-302 HLOWH15.6	
			10 < X < 30 ±0.5		
			30 < X < 100 ±1	图号 JF-JF15-HL-302-001A	
			ANGLE ±5°		
DRAWN BY	CHECKED BY	APPROVED BY			

为避免插口长度不够, 金手指位置加长1mm