

# 承認書

## APPROVAL SHEET

承認書編號:

SHEET NO: NDRJ1326040901

客 戶

CUSTOMER

品 名

PARTNAME

RJ13A1P-HL-SLN-XLN-H19.5-002

訂 單 號

PURCHASE ORDER

客 戶 料 號

CUSTOMER'S PART NO.

日 期

DATE

2026/4/10

客戶承認

Customer Approved by

供應商經辦

Supplier Handle by

發行章

**\* 承認後請回簽一份 Please sign back after approval. THANKS!**

香港公司 HONG KONG OFFICE:  
新昌電子(香港)有限公司  
XINCHANG ELECTRONIC(HK) LIMITED  
ADD: RM A10, 13/F, WAH WAI IND.  
BLDG., 1-7 WO HEUNG ST.,  
FO TAN, SHATIN, HK  
香港沙田火炭禾香街 1-7 號  
華威工業大廈 13 樓 A10 室  
E-mail: cynthia@gk-xc.com

常州工廠 CHANGZHOU FACTORY:  
江蘇國科新昌科技有限公司  
JIANGSU GUOKE XINCHANG  
TECHNOLOGY CO., LTD  
常州市新昌電子有限公司  
CHANGZHOU XINCHANG ELECTRONIC  
CO., LTD  
ADD: NO. 5 CHENGHE RD., LIJIA  
TOWN, CHANGZHOU, JIANGSU  
江蘇省常州市武進區禮嘉鎮  
城河路5號

E-mail:  
hong\_yin@gk-xc.com  
http://: www.gk-xc.com

東莞工廠 DONGGUAN FACTORY:  
東莞常新昌電子有限公司  
DONGGUAN CHANGXINCHANG  
ELECTRONIC CO., LTD  
ADD: RM 102, NO. 12 JIYUAN ST.,  
SHIJIE TOWN, DONGGUAN,  
GUANGDONG  
廣東省東莞市石碣鎮吉源街  
12號102室  
E-mail: tangfm@gk-xc.com

江苏国科新昌科技有限公司  
常州市新昌电子有限公司  
霍尔摇杆规格书

Houle, Joystick specs

适用机型：RJ13 系列

日期：2026 年 4 月 10 日

1.General 一般事项

1.1 Scope 适用范围

This specification is applicable to electromagnetic joystick used in electronic equipment. The device produces a linear response when the output voltage is within the specified voltage range. Outside this range, sensitivity is reduced and nonlinear

本规格书适用于电子设备使用之电磁摇杆。当输出电压在规定的电压范围内时，该装置产生线性响应。

在这个范围之外，灵敏度会降低，并且是非线性的

1.2 Standard atmospheric conditions 标准大气状态

Unless otherwise specified, the standard range of atmospheric conditions for making measurements

and tests is as follows:

除另有规定外，量测应在以下大气条件下进行：

Ambient temperature : 15°C ~ 35°C

温度

Relative humidity : 25% ~ 85%

相对湿度

Air pressure : 86 KPa~ 106 KPa

气压

If there is any doubt about the results, measurements should be made within the following limits:

如有任何疑虑时，量测应在以下条件下进行：

Ambient temperature : 20°C ± 1°C

温度

Relative humidity : 63% ~ 67%

相对湿度

Air pressure : 86 KPa~ 106 KPa

气压

1.3 Operating temperature range : -10°C ~ +70°C

适用温度范围

1.4 Storage temperature range : -30°C ~+80°C

保存温度范围

1.5 Operators shall wear electrostatic bracelets during operation

作业员操作时需戴静电手环

1.6 Construction 构造

Dimension 尺寸 : Refer to attached drawing 参见成品图

2. Mechanical Characteristics		2. 机械特性	
NO. 序号	Item 项目	Measuring condition 测试条件	Specifications 规格
	Figure of lever operation 摇杆动作形式	/	Circular operating 圆形式
2.1	Operation angle of lever 摇杆使用有效角度	Add a fit force on the lever top to push it to max,angle of each direction when lever is released and reset position . 当摇杆处于自由复归位置时,在摇杆顶部施加一定力将摇杆推向任意方向最大角度。	28° max 最大 28°
2.2	Operating force of lever 摇杆作用力	Test position is at more than 10 degrees deflection of lever 摇杆偏斜 10 度以上之位置测定	120±40 gf
2.3	Knob strength 扭曲强度	Apply force on the lever perpendicular to the lever's rotation direction 旋转于摇杆的力作用于摇杆上	More than 3Kgf.cm 3 seconds min 大于 3Kgf.cm 至少 3 秒钟
2.4	The stopper strength of the lever 摇杆止动强度	Apply side force on the lever perpendicular to the lever 's axial direction 垂直于摇杆的力作用于摇杆上	More than 3Kgf 3 seconds min 大于 3Kgf, 至少 3 秒钟
2.5	Accuracy of reset position of lever 摇杆复归精度	Measure the angle between the lever and the axial center line after the lever pushed to the direction of X-X(Y-Y)and resets 摇杆推向 X-X(Y-Y)方向自由复归后测量摇杆与垂直中心线的角度。	±3°
2.6	Pull strength of lever 摇杆拉拔强度	Apply specified push force on the lever upward 作用于摇杆上,沿摇杆方向向上	More than 5Kgf 3 seconds min 大于 5Kgf, 至少 3 秒钟

NO. 序号	Item 项目	Measuring condition 测试条件	Specifications 规格
2.7	Push Strength of lever 摇杆推强度	Apply specified push force on the lever downward 作用于摇杆上，沿摇杆方向向下	More than 10Kgf 3 seconds min 大于10Kgf,至少3秒钟
2.8	Switch operating force 开关作动力（适用于带开关机种）	Apply side force perpendicular to the lever's axial direction on the lever until the lever stops, measure the max force value 将一个轴向的力施加于摇杆上，直到其不动为止，量取施力期间之最大值。	750±300 gf
2.9	Switch travel 开关行程（适用于带开关机种）	Put the switch lever upward, apply 2 times of the static operating force over the lever's axial direction of the lever, measure the variance of the switch stroke. 将开关操作部位（摇杆）置于静止位置，并在操作柄中央施加两倍于作动力之静负荷测量柄被压到不动时之移动距离。	0.4+0.5/-0.3mm

### 3. Electrical characteristics

### 3. 电气特性

NO. 序号	Item 项目	Measuring condition 测试条件	Specifications 规格
3.1	Maximum Ratings 最大定格电压（适用于带开关机种）	Within (70°C) 70°C 以内	12VDC 50 mA
3.2	Contact resistance 接触阻抗（适用于带开关机种）	Apply 2 times of the operating force of the static load on the vertical direction of the lever, measure the resistance by using the Contact Resistance Tester with 1KHZ, 20mV, 5-50mA of current. 将两倍于作动力之静负荷加于操作柄之中央以（1KHZ, 20mV, 5-50mA）微电流接触阻抗计测定。	Less than 100m Ω 低于 100m Ω

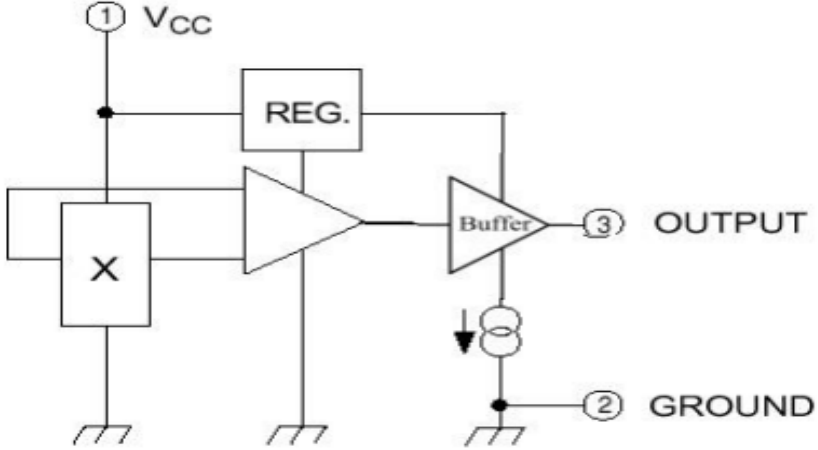
NO. 序号	Item 项目	Measuring condition 测试条件	Specifications 规格
3.3	Insulation resistance 绝缘阻抗 (适用于带开关机种)	A voltage of DC100V is applied between terminals. 以 DC100V 之电压加于端子间测定。	More than 100M Ω 100M Ω 以上
3.4	Withstand voltage 耐电压(适用于带开关机种)	A voltage of AC250V/20mA(50-60HZ) shall be applied for 1min between terminals 以 AC250V/20mA(50-60HZ)电压施加于端子间 1 分钟	Without breakdown 无绝缘破坏之现象
3.5	Voltage Divider Error 分压误差值	Voltage divider error is defined the ratio of the voltage terminals 1-2 to terminals 1-3 after the drive arm rested. 3.3V & 5V D.C. shall be applied to the terminals between 1 and 3 and then voltage divider error shall be measured with the drive arm operation on the line X-X and Y-Y. 分压误差值是摇杆自由复归后端子 1-2 与端子 1-3 电压比例。将 3.3V & 5V D.C 电压加在端子 1-3 之间, 分压误差值在摇杆动作于 X-X 和 Y-Y 方向到底复归后测试。(端子 1-2/端子 1-3 × 100%)	45% ~ 55%
3.6	Limit voltage value 极限电压值	The limit voltage value is the voltage ratio between terminals 1-2 and 1-3 after the rocker reaches the bottom Add 3.3V & 5V D.C voltage between terminals 1-3, and the limit voltage rocker operates in the x-x and Y-Y directions to the bottom 极限电压值是摇杆到底后端子 1-2 与端子 1-3 电压比例, 将 3.3V & 5V D.C 电压加在端子 1-3 之前, 极限电压摇杆运作于 X-X 和 Y-Y 方向到底测试。	At 28° Less than 0.65V 小于 0.65V
3.7	Functional Block Diagram 功能图	 <p>The diagram illustrates a functional block diagram. It starts with a power supply terminal labeled 'VCC' (1) connected to a regulator block 'REG.'. The output of the regulator is connected to a multiplier block 'X'. The output of 'X' is connected to the input of a buffer block 'Buffer'. The output of the buffer is connected to an output terminal labeled 'OUTPUT' (3). A ground terminal labeled 'GROUND' (2) is connected to the common ground of the multiplier and buffer blocks.</p>	

		Symbol 符号	Parameters 参数	Test Condition 实验条件	Min 最小值	Typ 标准值	Max 最大值	Unit 单位
3.8	Electrical Specificati 电气规格	Vcc	Supply Voltage 电源电压	Operating	1.6	3.3	5.5	V
		Icc	Supply Current 供电电流	Vcc=1.8V	-	0.8	1.1	mA
				Vcc=3.3V	-	1.4	1.8	mA
		Tpo	Power on Time 开机时间	$dvcc/dt \geq 5v/us$	-	-	30	us
			Min output voltage 最低输出电压	Vcc=3.3V	0	-	0.1	V
			Max output voltage 最高输出电压	Vcc=3.3V	3.2	-	3.3	V
		Bw	Bandwidth 带宽		-	5	-	KHZ
		Fc	Chopper Frequency 斩波频率		-	25	-	KHZ
		Ro	Output Resistance 输出电阻		-	-	120	ohm
		NF	NOISE 杂音	BW=10Hz-1 0K Hz	-	2.4	-	mVRMS

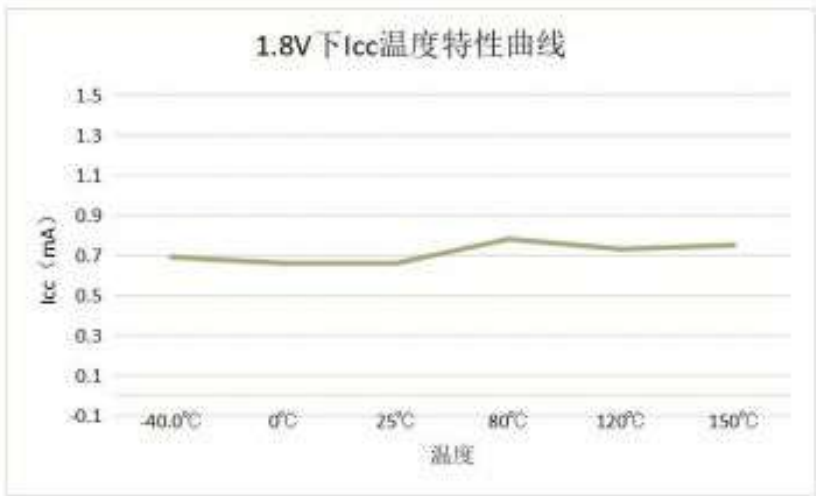
3.9	Magnetic Characteristics 磁特性	Symbol 符号	Parameters 参数	Test Condition 实验条件	Min 最小值	Typ 标准值	Max 最大值	Unit 单位
		LIN	Linearity 线性度		-1.5	-	1.5	%
		V <sub>o</sub>	Quiescent Voltage 静态电压	V <sub>cc</sub> =3.3v; B=0Gs	1.5	-	1.8	V
		V <sub>sen</sub>	Sensitivity performance 灵敏度	V <sub>cc</sub> =1.8v	1.7	2.1	2.9	mV/Gs
				V <sub>cc</sub> =3.3v	4.1	4.7	5.4	mV/Gs
			Magnetic field intensity range 磁场强度范围		±650	±1000	-	Gs
			Zero drift 零位漂移		-0.10	-	0.10	ppm/°C
	Sensitivity temperature drift 灵敏度温漂		-0.10	-	0.10	ppm/°C		
3.10	V ESD 耐静电	Type 类型			Reference 参考	Values 数值	Unit 单位	
		Human-body model(HBM) 人体类型			AEC-Q100-002	±3000	V	
		Charged-device model(CDM) 带电器件模型			AEC-Q100-011	±1000	V	
3.11	Supply Current vs, Temperature Characteristic Performance 电源电流与温度特性性能	 <p style="text-align: center;">1.8V下I<sub>cc</sub>温度特性曲线</p> <p style="text-align: center;">VCC=1.8V</p>						

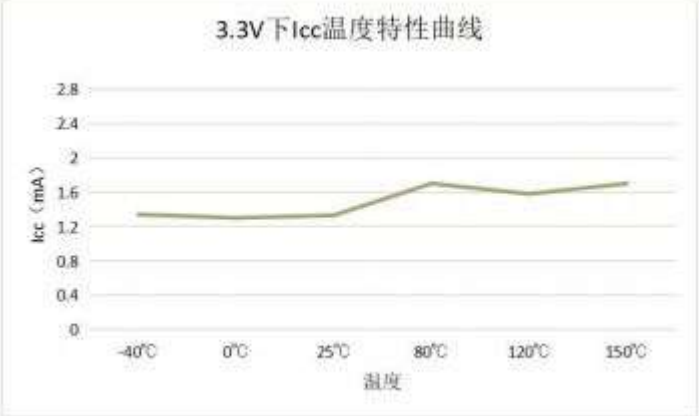
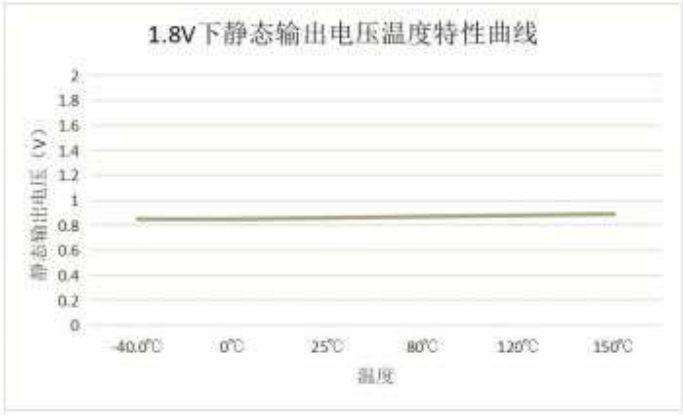
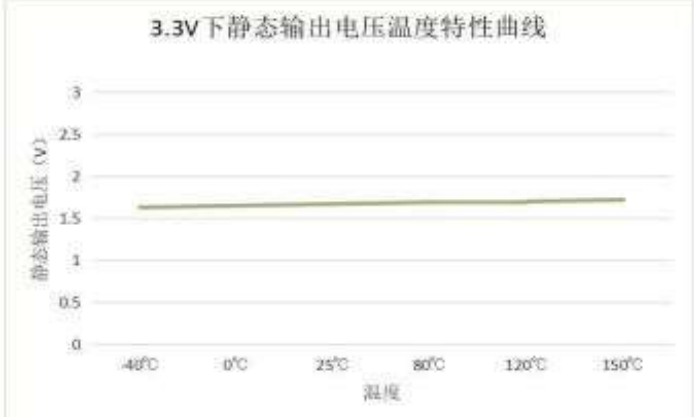
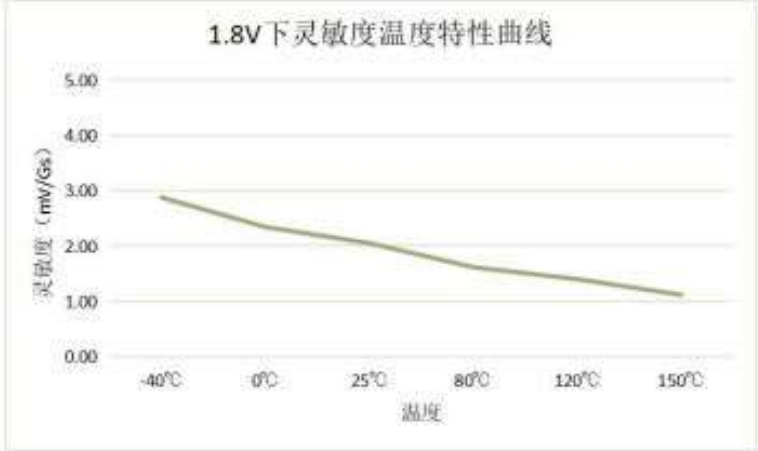
		 <p style="text-align: center;">VCC=3.3V</p>
3.12	<p>V null vs, Temperature Characteristic Performance 零电压与温度特性性能</p>	 <p style="text-align: center;">VCC=1.8V</p>  <p style="text-align: center;">VCC=3.3V</p>
3.13	<p>Sensitivity vs. Temperature 灵敏度与温度</p>	 <p style="text-align: center;">VCC=1.8V</p>

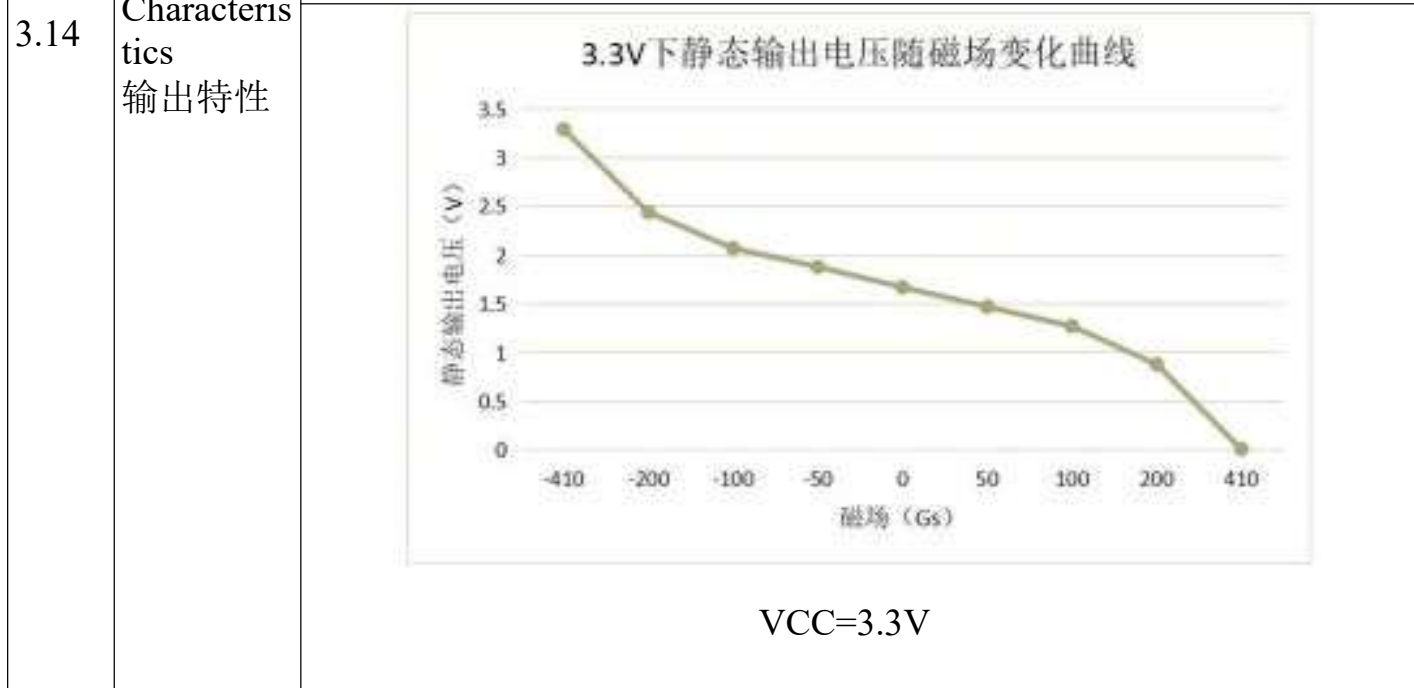
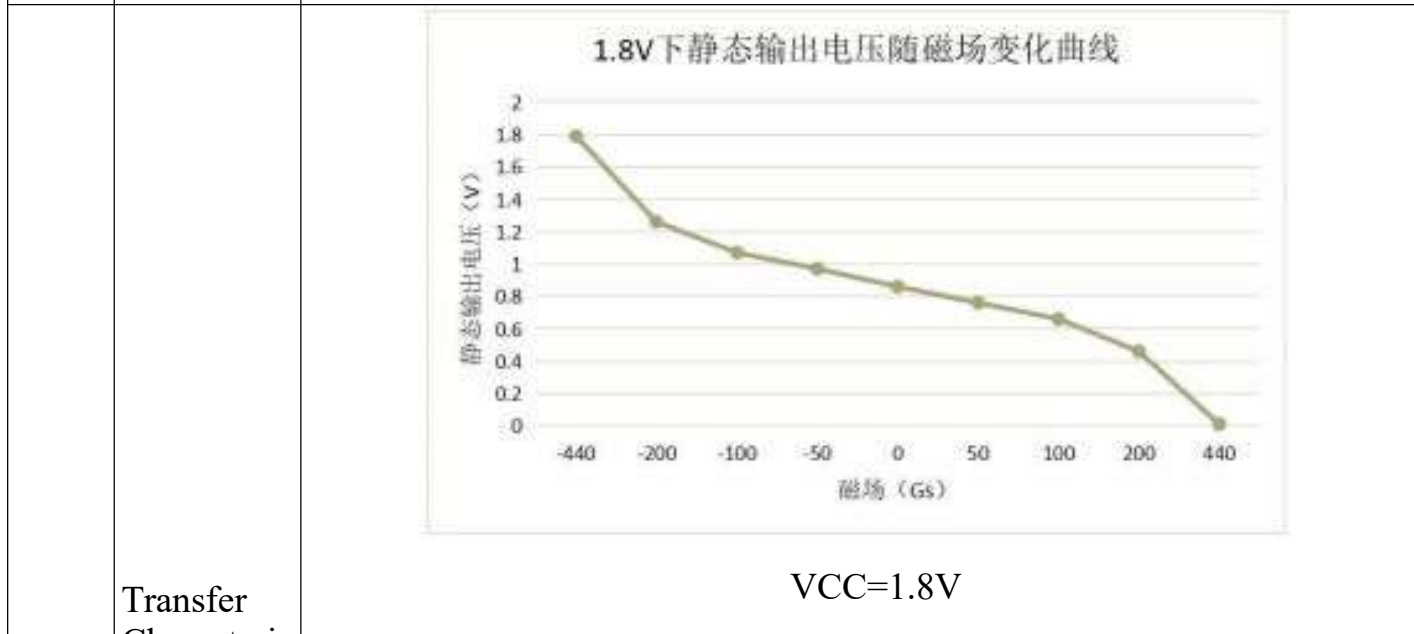
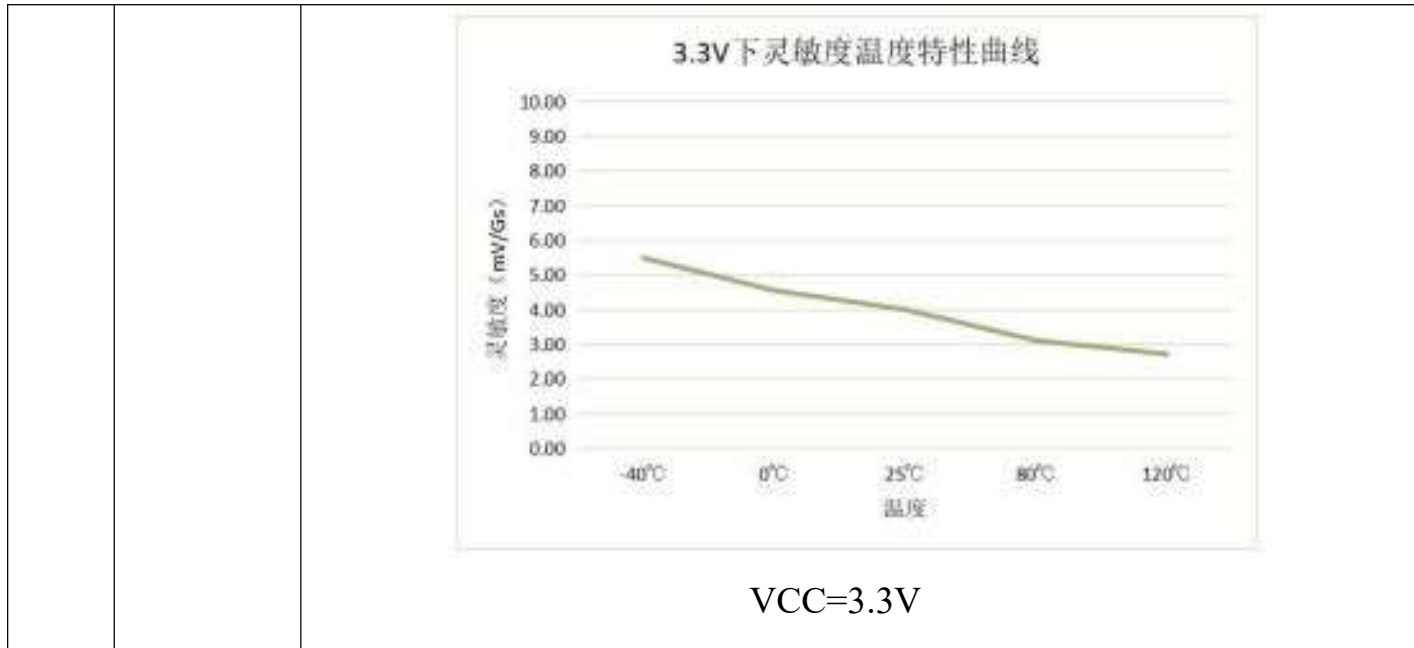

3.14

Transfer Characteristics  
输出特性

4. Endurance		4. 耐久特性	
NO. 序号	Item 项目	Measuring condition 测试条件	Specifications 规格
4.1	Dry heat 耐热性	Temperature: $80 \pm 2^{\circ}\text{C}$ Time: 96 hours The controller shall be subjected to standard atmospheric conditions for 2 hours, after which measurement shall be made. 在温度 $80 \pm 2^{\circ}\text{C}$ 恒温槽中放置 96 小时, 取出后在正常状态下放置 2 小时后测试。	Without damage and lever deformation, Without the looseness and failing function of witch 无不良性能产生, 无松动及开关性能损坏
4.2	Damp heat 耐湿性	Temperature: $60 \pm 2^{\circ}\text{C}$ Humidity : 90~95%Rh Time : 96 hours Surface moisture shall be removed And then the controller shall be subjected to standard atmospheric conditions for 2 hours, after which measurement shall be made. 温度 $60 \pm 2^{\circ}\text{C}$ 90%~95%Rh 恒温槽中放置 96 小时, 表面水份摄取后在正常状态下放置 2 小时后测试。	Without damage and lever deformation, Without the looseness and failing function of witch 无不良性能产生, 无松动及开关性能损坏
4.3	Cold 耐寒性	Temperature : $-30 \pm 2^{\circ}\text{C}$ Time : 96 hours Surface moisture shall be removed ,and then controller shall be subjected to standard atmospheric conditions for 2 hours, after which measurement shall be made . 在温度 $-30 \pm 2^{\circ}\text{C}$ 恒温槽中放置 96 小时, 表面水份摄取后在正常状态下放置 2 小时后测试。	Without damage and lever deformation, Without the looseness and failing function of witch 无不良性能产生, 无松动及开关性能损坏
4.4	Temperature cycling test 温度循环测试	Low temperature : $-20 \pm 3^{\circ}\text{C}$ 30minutes High temperature : $+60 \pm 3^{\circ}\text{C}$ 30minutes Number of cycles: 5 Surface moisture shall be removed, and then the controller shall be subjected to standard atmospheric conditions for 2 hours, after which measurement shall be made . 在低温为 $-20 \pm 3^{\circ}\text{C}$ 恒温槽放置 30 分钟, 高温 $60 \pm 3^{\circ}\text{C}$ 放置 30 分钟, 测试 5 次, 表面水份摄取后在正常状态下放置 2 小时后测试。	Without damage and lever deformation, Without the looseness and failing function of witch. 无不良性能产生, 无松动及开关性能损坏

NO. 序号	Item 项目	Measuring condition 测试条件	Specifications 规格
4.5	Resistance to soldering heat 焊锡耐热性	<p>Soldering test shall be using below materials. 使用以下材料进行焊锡试验。</p> <p>Using printed:single sided Wiring board copper clad laminate 使用板子 t=1.2mm 单面铜箔玻纤板</p> <p>Solder:Sn-Ag solder (Pb free ) 半田: Sn-Ag 材料 无 Pb</p> <p>Flux:specific gravity 0.82min 助焊剂: 比重 0.82 以上</p> <p>Soldering condition is in this below. 如下焊锡条件进行试验。</p> <p>Preheating: The surface of the solder side shall be heated 90°C to 100°C, for 45 seconds or less . 预热温度: 基板表面温度 90°C-100°C, 45 秒以内。</p> <p>Solder The board shall be solderd up to the mounting side surface (but solder shall not come into the mounting side surface )for within 5seconds at 255°C to 260°C 焊锡: 温度 255-260°C、5 秒以下。焊锡面最大为 PCB 板的上面。PCB 板表面无沾锡流动。</p> <p>Flux:The foaming method shall be applied .Flue shall not come into the mounting side surface and fluxing time shall be 3seconds or less . 助焊剂: 3 秒以内 PCB 表面喷撒, PCB 板上助焊剂流动。</p> <p>Soldering time :One time with above condition 焊锡次数: 按上記条件 1 次。</p>	<p>Not less than 95% of the surface dipped shall be covered with new solder 浸锡部分表面最少 95%被新锡覆盖。</p>
4.6	Soldering Heat 焊接加热	<p>Solder ing temperature is only allowed within 3±1 seconds at Max.250°C of copper foil surface after preheating. 焊接温度 250°C 以下, 仅允许时间 3±1 秒以内。</p>	 <p>The graph, titled 'WAVE SOLDERING CURVE', plots Temperature (TEMPERATURE) on the vertical axis against time (SECOND) on the horizontal axis. The curve starts with a horizontal segment, followed by a linear rise at a rate of 2~5°C/sec. This is followed by a horizontal plateau at 245~255°C for 3~4 seconds. The temperature then decreases linearly to 90°C, a process that takes 40~60 seconds. A preheating phase is indicated as 45~60 seconds at 100±10°C.</p>

NO. 序号	Item 项目	Measuring condition 测试条件	Specifications 规格
4.7	Free falling 自由落下试验	Height:75cm. Number of falls:3 times 从高度为 75 厘米落下测试 3 次后。	Without damage and lever deformation, Without the looseness and failing function of witch. 无不良性能产生, 无松动及开关性能损坏
4.8	Number of cycles 耐久寿命	Mechanical life should be tested 5,000,000 cycles at the speed of one cycle per second without electrical load when joystick rotate 360 ° at 26 ° position. 无负载状态下以 1 圈/秒速度将摇杆推到 26.0 ° 位置进行 360 ° 旋转测试, 寿命 5, 000, 000 圈	Without mechanical malfunction 机械性能无异常
4.9	Switch number of cycles 开关寿命(适用于带开关机种)	Under electrical load DC5V/5MA, compress 750gf force to the lever which is released and reset to vertical position .Switch life should be tested more than 2,000,000 cycles at the the speed of 2 cycles of 2 cycles per second . 负载状态下 (DC5V/5mA) ,在摇杆自由复归后的垂直方向施加 750gf 的按压力, 以 2 次/秒的速度对开关进行测试, 寿命 2, 000, 000 次以上。	Contact resistance 200ΩMax, No mechanical malfunction Be satisfied with 2.8 and 2.9 接触阻抗最大 200 Ω , 机械方面能动作 (符合第 2.8 条和第 2.9 条

印 章	日期: 2026-4-10	
	<b>江苏国科新昌科技有限公司</b> <b>常州市新昌电子有限公司</b>	

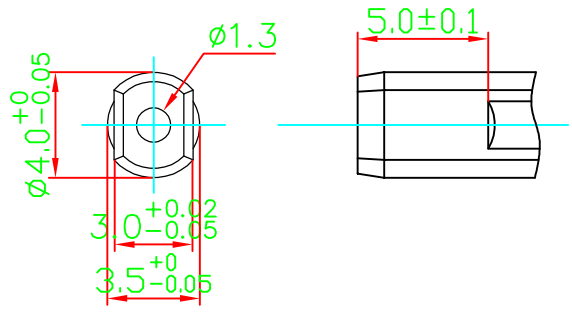
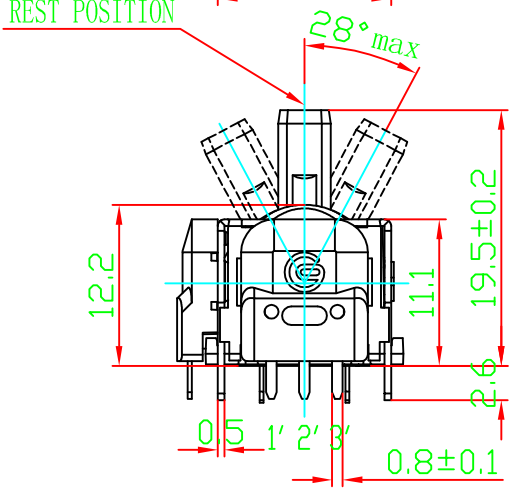
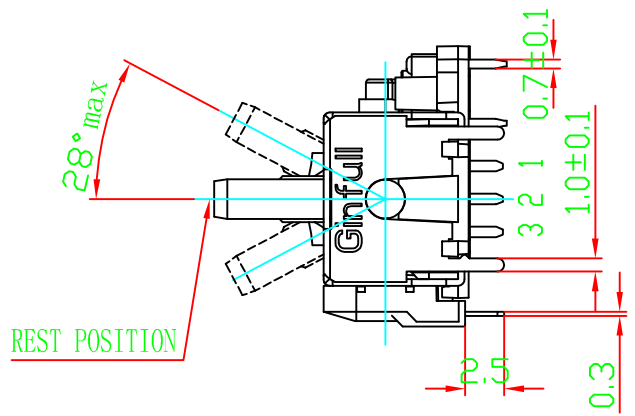
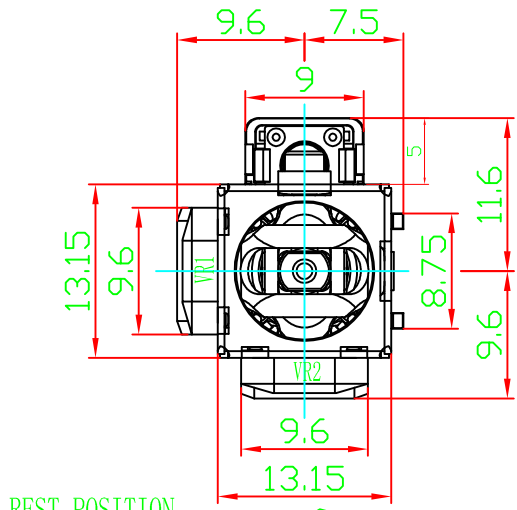

推柄局部尺寸详图  
2:1

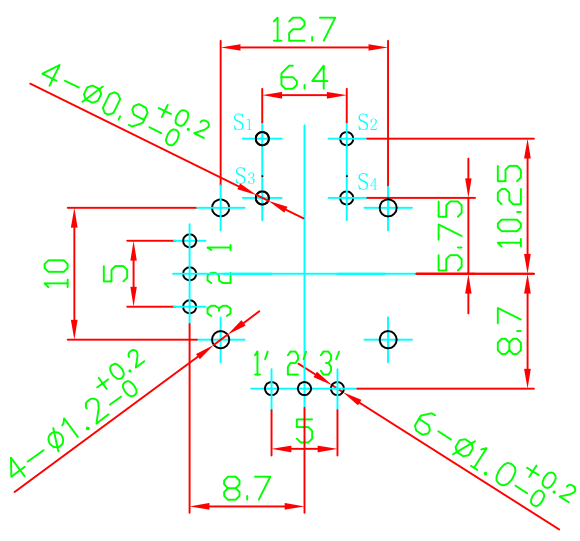

PCB安装孔详图

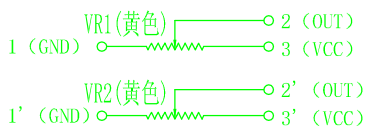

CIRCUIT: VR

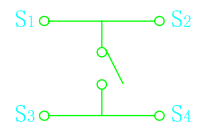

CIRCUIT: SW

				江苏国科新昌科技有限公司 常州市新昌电子有限公司	
				Projected view	机种
NO.	DESCRIPTION	DATE	TOL UNLESS OTHERWISE STATED		霍尔胶杆
DRAWN BY	CHECKED BY	APPROVED BY	X < 10 ±0.3		品名
			10 < X < 30 ±0.5		RJ13A1P-HL-SLN-XLN-H19.5-002
			30 < X < 100 ±1		图号
			ANGLE ±5°		JF-RJ13A1P-HL-002A

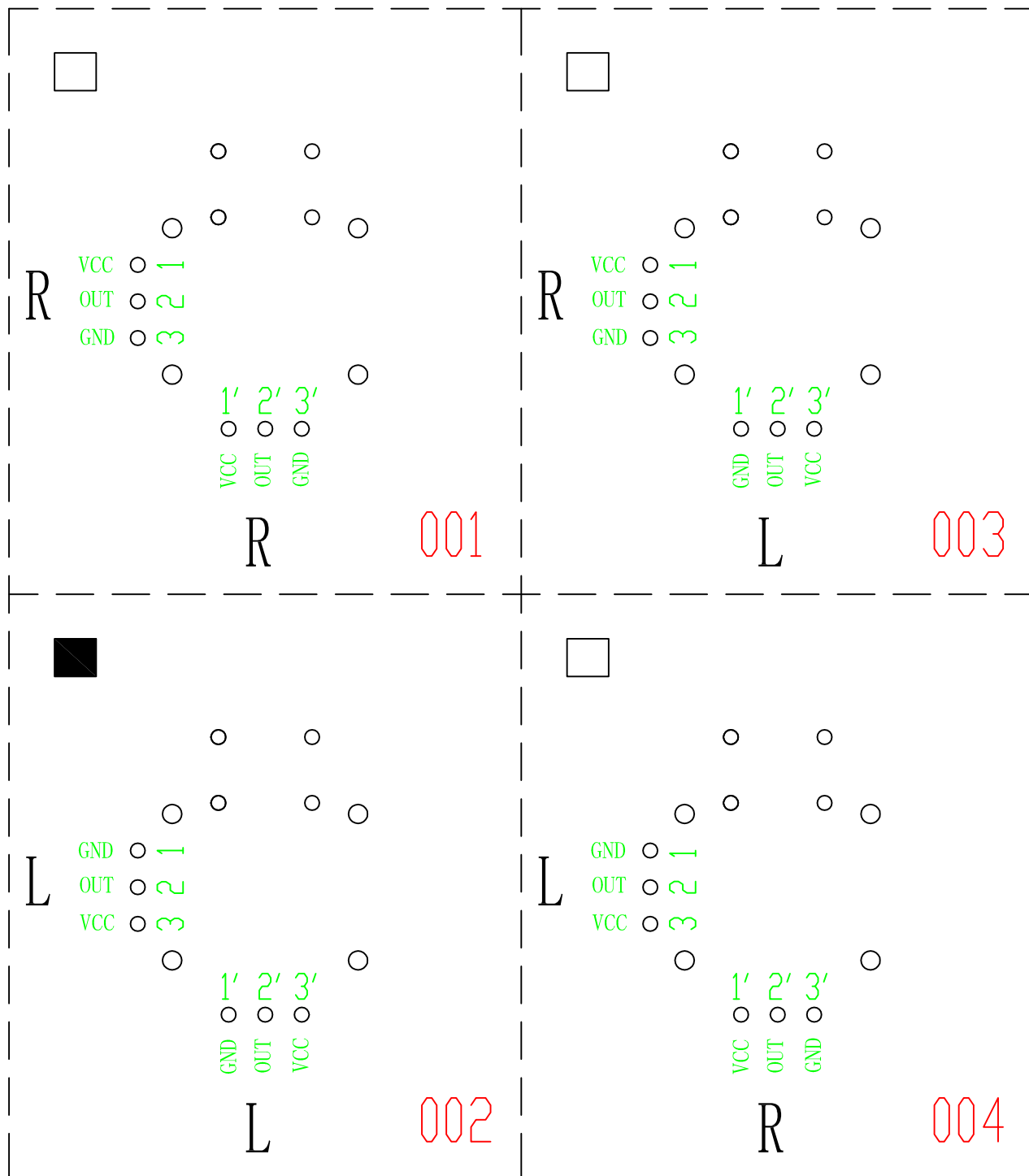

1. 霍尔：L代表1脚接地（本体黄色）  
R代表3脚接地（本体黑色）
2. 接线方式共有4种001和002为通用型首选；  
001为两个黑色本体，002为两个黄色本体。
3. 此视图为PCBA正面。
4. 所有款式的磁铁N极朝芯片方向安装。